

ABB MEASUREMENT & ANALYTICS

Sensi+ NG

Natural gas quality monitoring



A single analyzer for continuous measurements of multiple natural gas contaminants for custody transfer, tariff compliance, and process monitoring

Natural gas measurement made easy

Fast, accurate and reliable measurement of H₂S, H₂O, O₂ and CO₂ in natural gas streams

Designed for peace of mind

- Fast response time for quick actions to process upsets
- Accurate measurement and low cross-interference generating fewer false results, positive or negative
- Designed for reliability with low cost of ownership and maintenance
- Less costly unplanned interventions due to unexpected failures

Modern product delivering more than expected

- User-friendly interface for quick access to in-depth data
- Remote access displaying comprehensive information
- AnalyzerExpert features providing expert actions, insights and self-diagnostics directly on your instrument

Product overview

—
01 Sensi+ NG modern design and technology enables quick servicing and highly reliable measurement

The Sensi+ NG series of instruments are laser-based analyzers designed for measuring multiple con-taminants in process streams. They are designed for use in remote and hazardous locations where they provide superior performance, low cost of ownership and fast response to process upsets.

The Sensi+ NG model is specifically designed for continuous monitoring of gas con-taminants in post-processing and pipeline-quality natural gas streams by targeting H₂S, H₂O, O₂ and CO₂. Real-time monitoring of contaminant levels allows the triggering of threshold alarms to redirect contaminated streams that would otherwise compromise safety and operational yield. The unit itself is a wall-mounted analyzer based on the ABB-patented Off-Axis Integrated Cavity Output Spectroscopy (OA-ICOS) laser-spectrometer

technology.

Benefits

- **A single analyzer for multiple natural gas contaminants: H₂S, H₂O, O₂ and CO₂**
 - Obviate need for multiple analyzers, simplifies deployment, operation and service
- **Fast response in measuring contaminants**
 - Maximize gas network uptime, minimize product waste, ensure safety and productivity
- **Analyzer accuracy and reliability**
 - ICOS technology brings high dynamic range measurements with no compromise on performance for confident gas network operation (no false shut-ins, no missed upsets)
- **Simple to use, operate and service**
 - Zero consumables, field serviceable, simple and comprehensive user interface, lowering OPEX

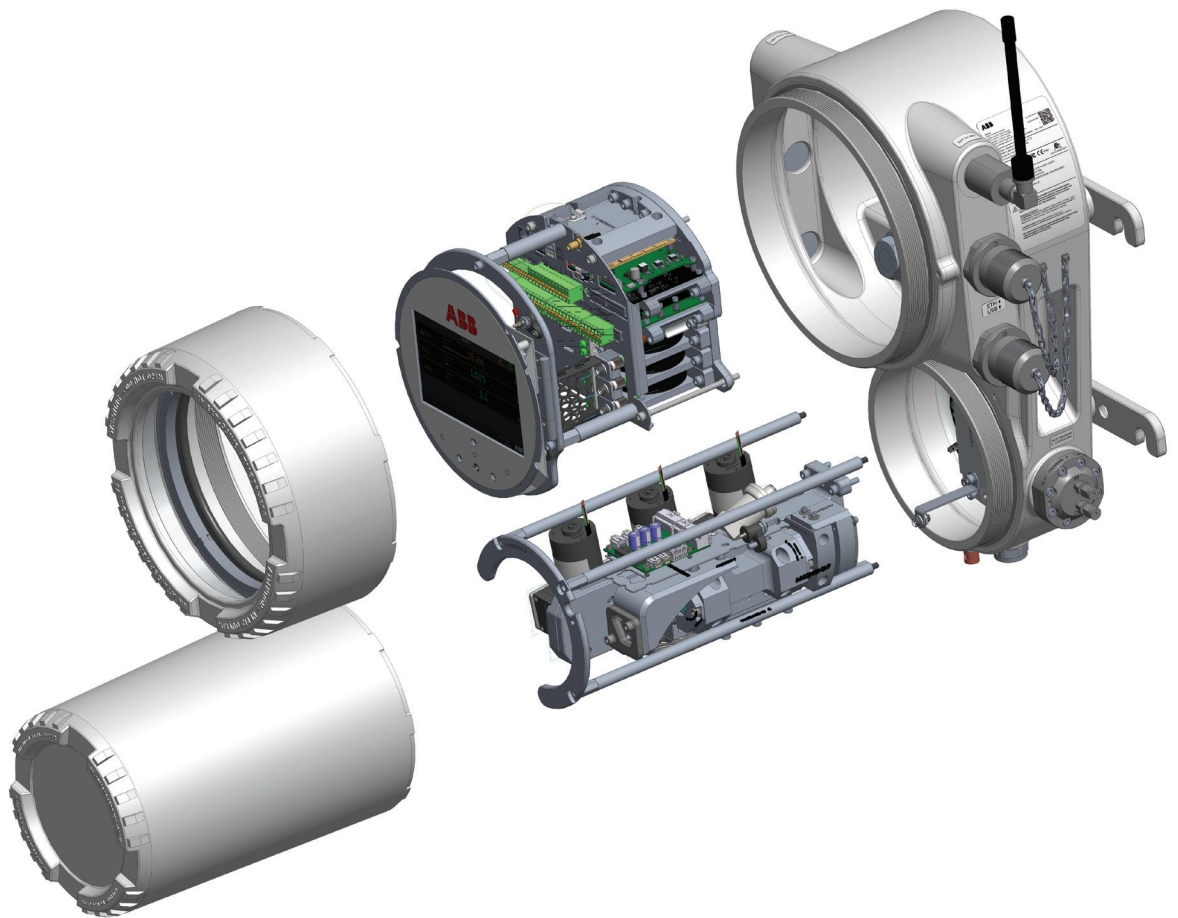

Product features

01 Sensi+ NG external features and connectivity

- Multiple contaminant options: H₂S, H₂O, O₂ and CO₂
- Flameproof design with dual seal for installation in hazardous areas without complex purging systems
- Instrument accuracy practically unaffected by cross-interferences
- Low sample flow rate to reduce environmental costs and gas waste
- Dual seal, no additional process seal required
- Super low long-term drift, eliminating the need for frequent calibration

AnalyzerExpert™ Inside Sensi+ NG

The Sensi+ NG analyzer is loaded with AnalyzerExpert™ features that provide expert actions and insights directly from your instrument.

- Wavelength initialization and control
- Laser auto-tuning
- Self-diagnostics
- Automated line-locking on spectrum
- Real-time cross-interference compensation
- Comprehensive alarms
- Health metrics monitoring

Dynamic QR Code and AutoID assistance for analyzers

ABB's Dynamic QR Code assistance for analyzers is a unique feature that enables comprehensive product health checks and effective troubleshooting without physically connecting to your system. In addition to providing static information for analyzer identification from the AutoID feature, the QR code contains dynamic information on analyzer configuration and current health status. ABB specialists can use this data to identify the problem and provide a rapid response solution.

[Find out more about DQR](#)

Cyber security

ABB strives to maintain cyber security for its products and services. This product has been designed to meet ABB's cyber security standards. It features enhanced system integrity, data protection and much more.

[Find out more about ABB cyber security](#)

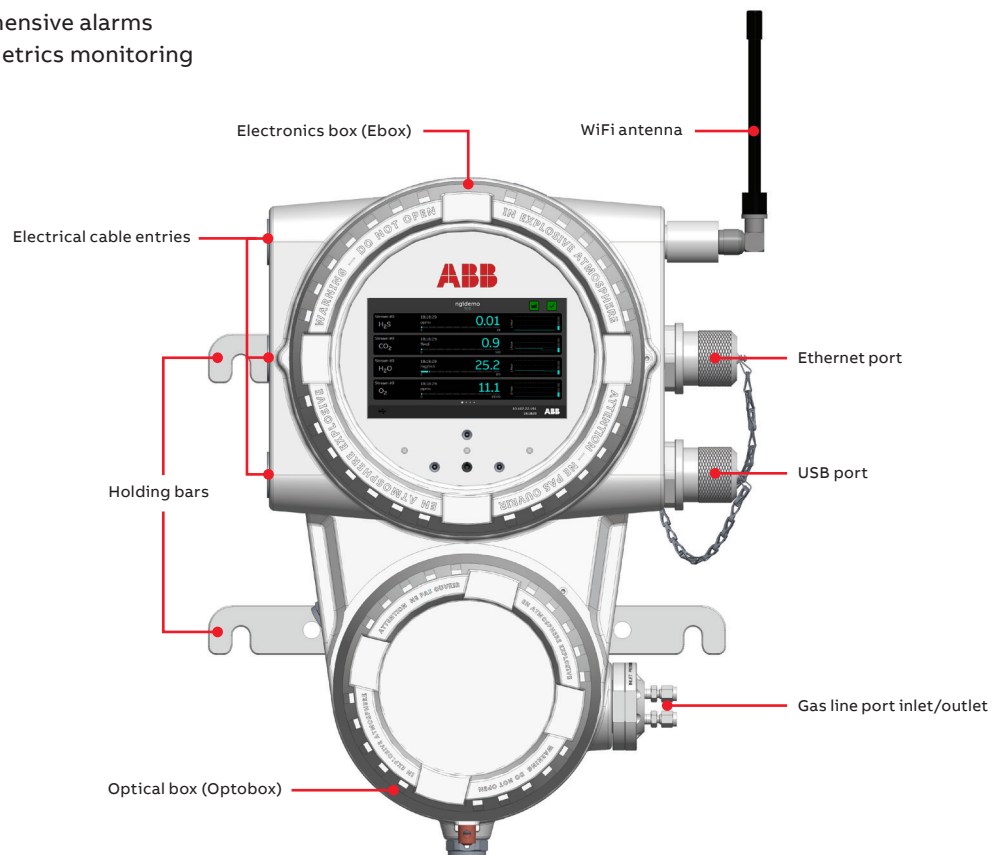

User interfaces

01 Web Remote GUI

The analyzer provides state-of-the-art local and remote user interfaces for quick and in-depth information.

Local Human Machine Interface (HMI)

Sensi+ NG is equipped with a 7-inch screen, three informational LEDs and a gesture control system. The local HMI provides multiple panels that display detailed information:

- Measurements
- Alarms
- Basic and advanced diagnostics
- System information

Maintenance

While keeping a small maintenance schedule, the Sensi+ NG is designed for easy serviceability. This analyzer was designed from the ground up to be maintained by personnel with little or no prior knowledge of spectroscopic instruments.

Both hardware and software are designed to provide low maintenance through easily accessible and in-the-field replaceable parts such as:

- Filters
- Detector
- Pump manifold
- Proportional valve assembly
- Wetted path assembly

Software maintenance support features:

- Self-diagnostics
- Analyzer components health status validation
- Direct access to user manual and service guides
- Comprehensive alarms and event acknowledgement

Remote Graphical User Interface (GUI)

The remote GUI is an HTML-based user interface that provides in-depth information and configuration without the need for proprietary software. It provides multiple accesses and menus such as:

- Measurements panel
- Settings and configuration panels for gas parameters, physical interfaces and general instrument parameters
- Alarm display, acknowledgement and information
- Process events
- Reports and export of historical data
- Systems information

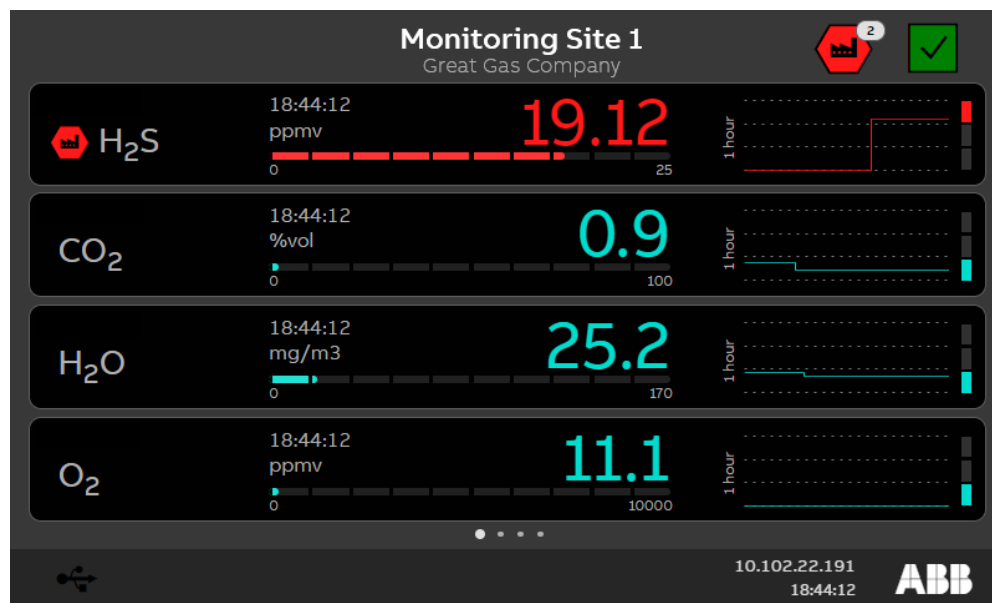

Product specifications

Item (gases)	H ₂ S	H ₂ O	CO ₂	O ₂
Linear range	0 to 100 ppm	0 to 500 ppm	0 to 40 %	0 to 7,000 ppm
Repeatability (1 standard deviation)	±0.05 ppm or ±0.25 % of reading	±0.5 ppm or ±0.5 % of reading	±50 ppm or ±0.25 % of reading	±1 ppm or 0.25 % of reading
Limit of detection (3 standard deviations)	0.15 ppm	1.5 ppm	150 ppm	3 ppm
Minimum detectable change ¹	0.2 ppm	2 ppm	150 ppm	5 ppm
Accuracy ²	±0.2 ppm or ±2 % of reading	±2 ppm or ±2 % of reading ³	±200 ppm or ±2 % of reading	±5 ppm or ±2.5 % of reading ⁴
Drift (1 year) ⁵	±0.1 ppm or ±1 % of reading	±2 ppm or ±1 % of reading	±100 ppm or ±1 % of reading	upcoming ⁶
Measurement update time	1.5 seconds	1.5 seconds	1.5 seconds	1.5 seconds
Rise (fall) time (T10-90)	<10 seconds	<35 seconds	<10 seconds	<25 seconds
Trending range	100 to 10,000 ppm	500 to 20,000 ppm	40 to 100 %	7,000 to 30,000 ppm

¹ Minimum detectable change, As per IEC 61207 definition, is twice the average peak-to-peak output fluctuation measured over 5-minute periods.

² Accuracy includes uncertainties for linearity, gas stream composition cross-interference, and ambient temperature influence.

³ H₂O accuracy from cross-interference increases to ±3 ppm or ±2 % of reading when H₂ exceeds 15 %.

⁴ O₂ accuracy from cross-interference increases to ±5 ppm or ±5 % of reading when CO₂ exceeds 20 %.

⁵ Drift based on periodic measurements of a consistent cylinder over the course of more than one year without intermediary calibration.

⁶ O₂ results will be published after one year of data collection.

Gas line specifications

Inlet port pressure

- 35–50 kPa gauge (5.0–7.25 psig)

Outlet port

- Vent to atmosphere
- Maximum outlet back pressure: 10 psig

Sample flow rate

- Typical 0.2–0.4 SLPM (0.007–0.014 scfm)

NPT compression fitting 1/8" tubing

With flame arrestor and inlet filter

Environmental conditions

Operating temperature

- –14 to 55 °C (7 to 130 °F)

Storage temperature

- –30 to 60 °C (–22 to 140 °F)

Electrical

Supply voltage

- 10.5–30 VDC

Power consumption

- Nominal: 50 W
- Max (peak at startup <15 s): 100 W
- Peak current: 10 A

Mechanical

Dimensions (W×H×D)

- 43.2 cm × 52.5 cm × 39.8 cm
(16.9 in × 20.6 in × 15.4 in)

Weight

- 50 kg (110 lb)

Ingress protection

- IP66/TYPE 4X

Cable entries

- M32 SI or 1" NPT cable glands

Internal inputs/outputs

- 4 × 4–20 mA analog output
- 2 × 9–30 V digital Input
- 10 × solid-state relays
- Ethernet

External service and maintenance ports

- Ethernet port
- USB port

Supported protocols

- Modbus TCP/IP
- Wi-Fi 802.11a/b/g/n 2.4 GHz (optional)

Security

- ABB's internal cyber security standards

Certifications

- Class I, Division 1, Groups B, C, D T6
- Class I, Zone 1, AEx/Ex db IIB + H2 T6 Gb
- Ex db IIB + H2 T6 Gb
- ATEX/UKCA II 2 G Ex db IIB + H2 T6 Gb

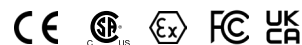

Wallmounted

Sensi+ NG gas analyzers are designed to be fitted on strut channels.



Options and configurations

Accuracy

Sensi+ NG benefits from the high accuracy and large dynamic range inherent to the ICOS technology. Its accuracy has been optimized for precise monitoring of typical tariff levels within the linear range. The accuracy is independent from the maximum range, thus eliminating the need to select a limited range analyzer. At higher levels, it continues to make reliable measurements throughout the trending range.

Use software settings to place your 4–20 mA and other outputs at the range relevant to your process.

WiFi antenna

Select the optional WiFi antenna to access your Sensi+ NG directly with any web browser.

- Frequency: 2.4 GHz
- Max Gain: 2.0 DBi

Sample conditioning system (see page 8)

ABB can provide a fit-for-purpose sample conditioning system specifically designed to fit on the strut channels behind the Sensi+ NG, with the right clearance and dimensions for easy installation, maintenance and operation.

- Includes all stainless parts
- Variable area flowmeters inlet/outlet
- Bypass to switch between process stream and validation gas
- Membrane separator
- Pressure regulator
- Mounted on a base plate designed to fit on the Sensi+ NG and wall-mount struts

Gas stream composition

The Sensi+ NG natural gas analyzer, will meet measurement specifications in typical gas stream composition. Additionally, Sensi+ NG is insensitive to mercaptans.

Outside of these ranges, ABB's application team will validate attainable performances and can design chemometric models for purpose to your gas composition.

Natural gas

Component	Symbol	Typical range (Mol %)
Methane	C1	65–100
Ethane	C2	0–20
Propane	C3	0–15
Butanes	C4s	0–5
Pentanes	C5s	0–2
Hexanes and heavier	C6+	0–2
Carbon dioxide	CO ₂	0–20
Nitrogen	N ₂	0–10
Hydrogen	H ₂	0–20

Renewable natural gas (biogas)

Component	Symbol	Typical range (Mol %)
Methane	C1	55–100
Carbon dioxide	CO ₂	0–40
Nitrogen	N ₂	0–5

*Gas stream composition shall be supplied as soon as possible in the ordering process.

Sample conditioning system option

01 Plan space of sample conditioning system

02 P&ID of sample conditioning system

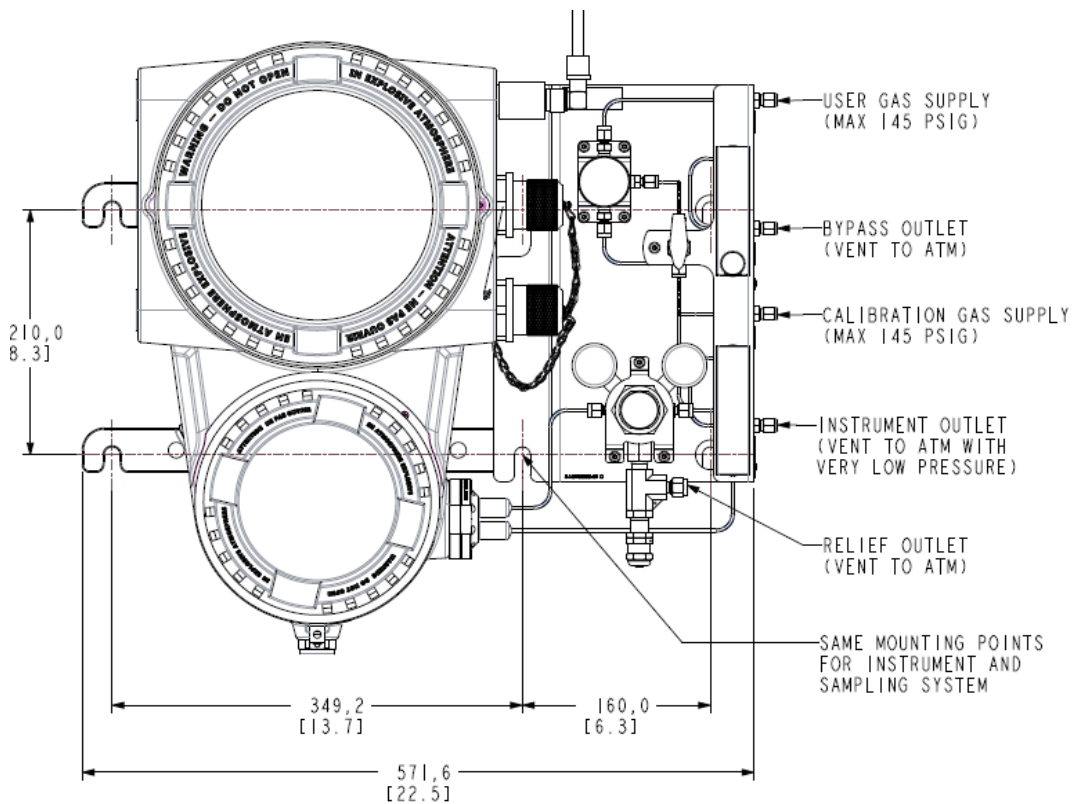

01

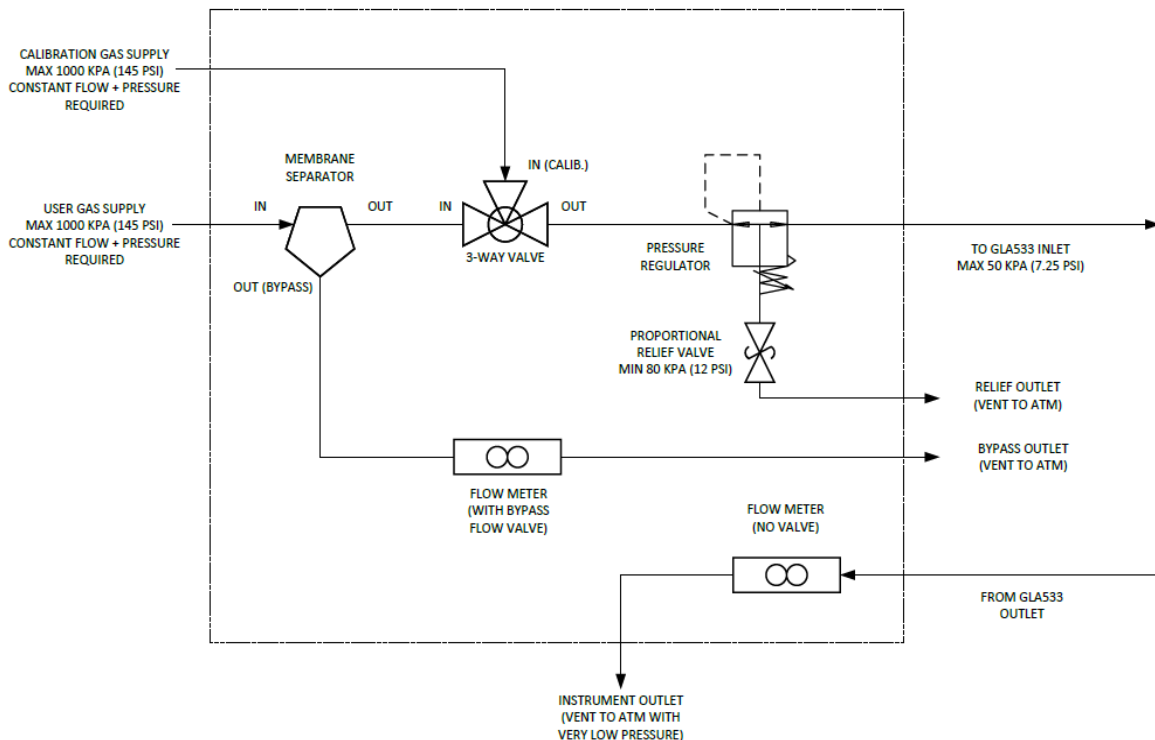

02

Dimensions

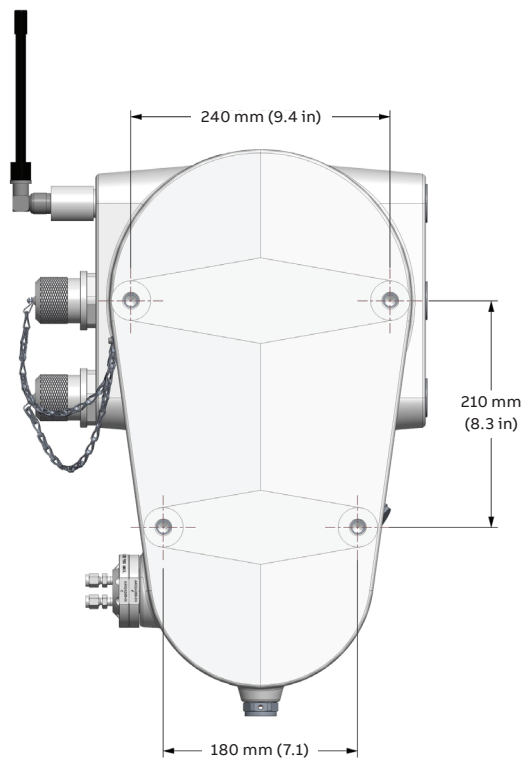
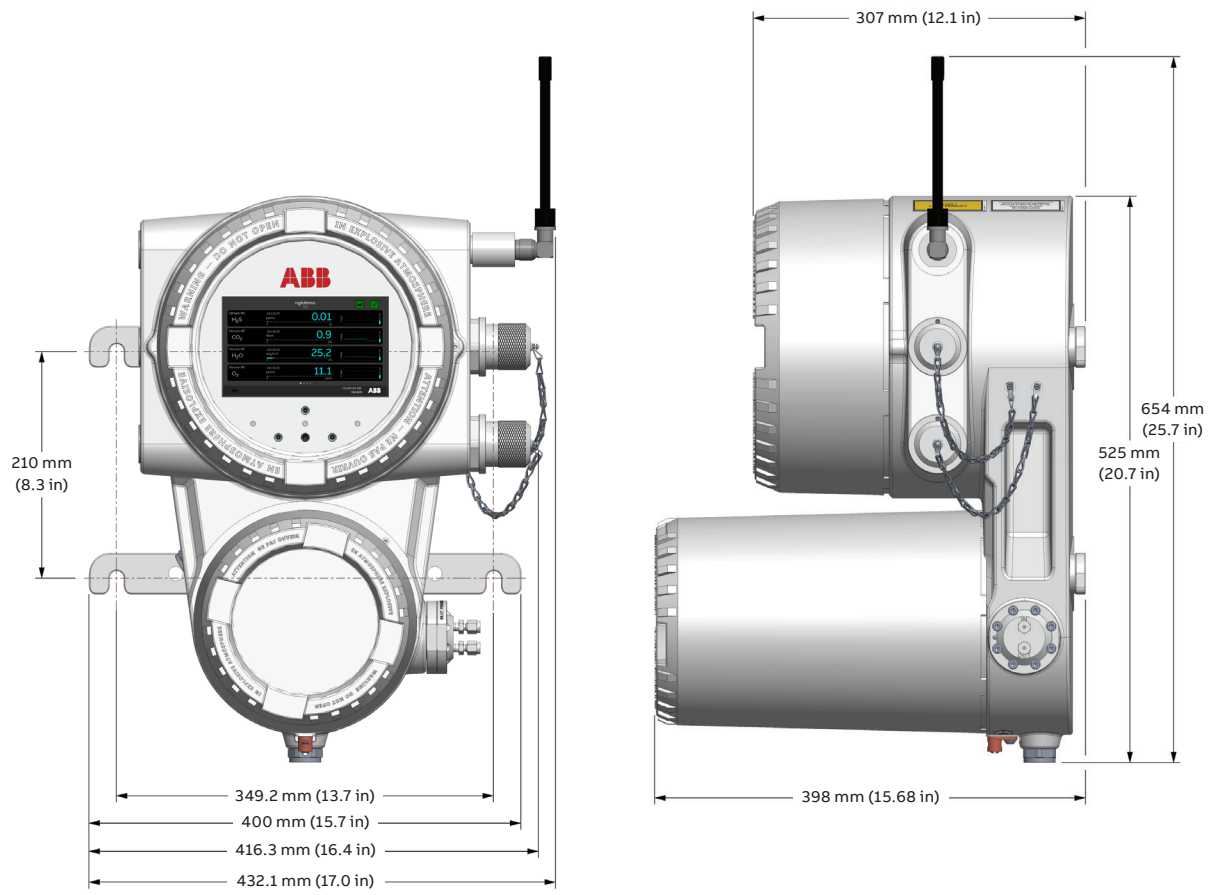

Ordering information

Sensi+ NG	Main code				Optional code	
	XXXX	XX	XXX	AL	R	XX
Measured component						
H ₂ S	S					
H ₂ O	M					
O ₂	O					
H ₂ S + CO ₂	SC					
H ₂ S + H ₂ O	SM					
H ₂ S + O ₂	SO					
H ₂ O + O ₂	MO					
H ₂ S + H ₂ O + CO ₂	SMC					
H ₂ S + O ₂ + CO ₂	SOC					
H ₂ S + H ₂ O + O ₂	SMO					
H ₂ S + H ₂ O + CO ₂ + O ₂	SMOC					
Optional WiFi antenna						
WiFi installed		WF				
Without WiFi		WO				
Cable entry options						
M32 cable glands			M32			
1" NPT cable glands			NPT			
Sampling system						
None						(Blank)
Standard sample conditioning system						S1



—

ABB Inc.

Measurement & Analytics

3400, rue Pierre-Ardouin
Québec, Québec
G1P 0B2 Canada

1 800 858-3847 (North America)
Tel.: +1 418-877-2944 (Worldwide)
Fax: +1 418-877-2834
Email: icos@ca.abb.com

abb.com/measurement

Additional information

We reserve the right to make technical changes or modify the contents of this document without prior notice. With regard to purchase orders, the agreed particulars shall prevail. ABB Inc. does not accept any responsibility whatsoever for potential errors or possible lack of information in this document.

We reserve all rights in this document and in the subject matter and illustrations contained therein. Any reproduction, disclosure to third parties or utilization of its contents – in whole or in parts – is forbidden without prior written consent of ABB Inc.

© ABB, 2025
Specifications subject to change without notice.